



STAR WARS



MOC-77452

NEW REPUBLIC
V-WING AIRSPEEDER
(LEGENDS)

555
pcs/pzs



DESIGNED BY



APOCRYPHER

STAR WARS
ROGUE SQUADRON

PREFACE

My Name is Jonathan, and I am a French-Canadian AFOL with a love for Star Wars, and more specifically, it's ships.

I now hold a career in the video game industry as a Game & Level Designer.

That being said, I wouldn't be where I am today if it were not for all 3 of these things this project centers around :
Video Games, Star Wars and LEGO. 3 of my greatest influences and passions reunited in a tribute to what shaped me today!

Those of you who know this ship like I do from the Rogue Squadron game will remember how powerful, fast and fun this ship was to play with!

Since there are few builds of this ship around, I decided to challenge myself and create one worthy of an Official LEGO Build. I created the model digitally through the use of Stud.io and constrained myself to the same criterias you would expect from an official LEGO build - Quality, Accuracy, Solidity, Stability, Techniques and Optimization.

This project is actually my first MOC to transcend from Digital to Physical realisation!

I hope you enjoy this build as much as I did undertaking its creation!



Mon nom est Jonathan, et je suis un Canadien Francais Fan de Lego Adulte avec un amour pour Star Wars, et plus spécifiquement, les vaisseaux de ceux-ci!

Je détiens maintenant une carrière dans l'industrie du Jeu Vidéo en tant que Concepteur de Jeu & Niveaux.

Cela-dit, je ne serais pas ou j'en suis aujourd'hui si ce n'était pas des 3 choses auquel ce projet focus: Les Jeux Vidéo, Les LEGOs et Star Wars. 3 de mes plus grandes influences et passions réunis dans un hommage à ce qui m'a forgé aujourd'hui!

Ceux qui connaissent ce vaisseau du jeu Rogue Squadron comme moi se rappellent sûrement à quel point il était puissant, rapide et amusant à jouer avec!

Puisqu'il y a peu de projets de ce véhicule, j'ai voulu me faire un challenge personnel et en créer un digne d'un produit LEGO officiel. J'ai créé le model digitallement a l'aide du logiciel Stud.io et je me suis contraint au même critères auquel vous pouvez vous attendre d'un vrai produit LEGO : Qualité, Fidélité, Solidité, Stabilité, techniques et optimisation.

Ce projet est actuellement mon premier projet qui franchit le seuil du digital à la réalisation physique!

J'espère que vous aimerez cette construction autant que j'ai eu de plaisir à le concevoir!

Cheers! Au Plaisir!



Jonathan D.M
// APOCRYPHEA

ORIGINS

The V-Wing Airspeeder is a vehicle used by the New Republic following the defeat of the Empire in the original trilogy. It first appeared in the *Star Wars: Dark Empire* comics, first published in 1991. It debuts in the *Battle of Mon Calamari* from that extended universe storyline (which is now non-canonical).

The ship makes its first digital appearance in the *Star Wars: Rogue Squadron Video Game* in 1998, on both the *Nintendo 64* console and PC. The final mission of the game is a recreation of the earlier mentioned *Battle of Mon Calamari* in the *Dark Empire* comics, where the player flies the V-Wing Airspeeder as Wedge Antilles.

Since then, it has appeared in a few other *Star Wars* medias - However, this was all part of the Expanded Universe before it became part of the *Star Wars Legends* continuity in 2014. Furthermore, fans may know a different ship also named as a V-Wing - the Alpha-3 Nimbus starfighter, first appearing in Episode III. These two ships are completely different and unrelated to one another.

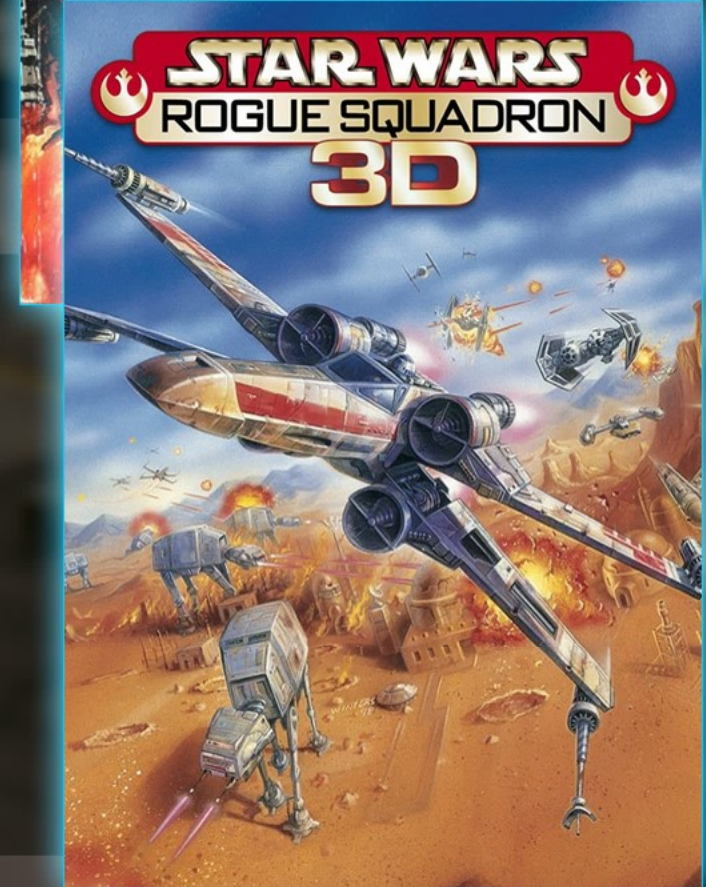
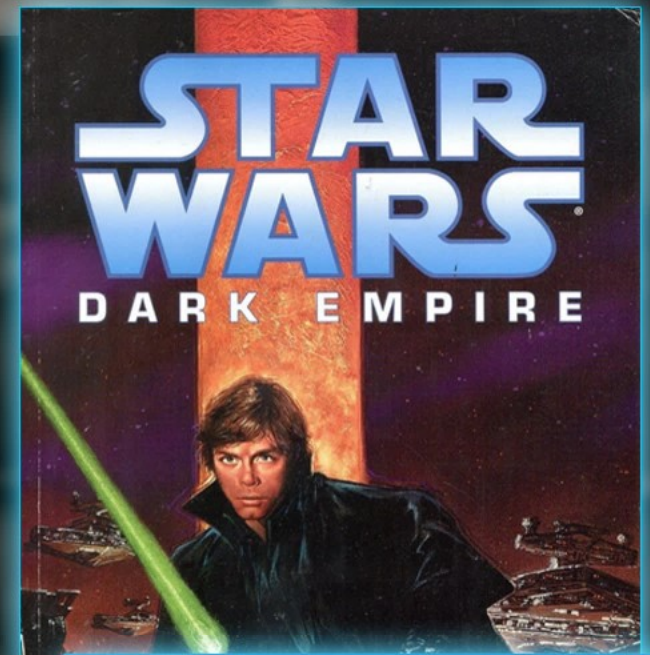

ORIGINES

Le Airspeeder V-Wing est un véhicule utilisé par la nouvelle République suivant la défaite de l'Empire dans la trilogie originale. La première apparence du vaisseau remonte en 1991, dans les bandes dessinées *Star Wars: L'Empire des Ténèbres*. Il débute lors de la Bataille de Mon Calamari au courant de l'histoire de cette série (qui est maintenant non-canonique).

Le vaisseau fait sa première apparence digitale en 1998 dans le Jeu Vidéo *Star Wars: Rogue Squadron*, sur la console *Nintendo 64* et sur PC. La mission finale du jeu est une récréation de la Bataille de Mon Calamari mentionnée ci-haut, où le joueur a l'occasion de piloter le V-Wing en tant que Wedge Antilles.

Depuis, il est apparu dans quelques autres médias *Star Wars* - Toutefois, tout cela fait partie de l'univers étendu de *Star Wars*, qui est devenu les *Légendes Star Wars*, une continuité non-officielle - en 2014. De plus, les fans peuvent connaître un modèle différent de vaisseau intitulé 'V-Wing' - Le Chasseur Alpha-3 Nimbus, apparaissent dans l'Episode III. Ces 2 vaisseaux sont complètement différents de l'un et l'autre.



SPECIFICATIONS

A single pilot airspeeder, conceived to defend planetside and leave the space combat to more expensive fighters, the V-Wing Airspeeder is a repulsorlift powered craft equipped with an Ion engine and Scramjet Boosters capable of incredible speeds. It is also equipped with twin linked rapid fire blaster cannons. Rapid deployment, high speed, low cost and maintenance made it invaluable to the fledgling New Republic.

Un speeder à pilote unique, conçu pour défendre l'espace aérien planétaire, dans l'optique de laisser les opérations de combat spatial aux chasseurs plus dispendieux. Le V-Wing est équipé de Repulsorlifts, un moteur Ion et des boosters Scramjet, le permettant d'atteindre une vitesse incroyable. Il est aussi équipé de canons jumeaux à tirs rapides. Déploiement rapide, haute vitesse, coûts et maintenance faibles en font un outil indispensable pour la Nouvelle République en croissance.

Manufacturer: Slayn & Korpil
Length: 6.3 M

Speed: 1000 KM/H
(1400 w/ Scramjet Booster)

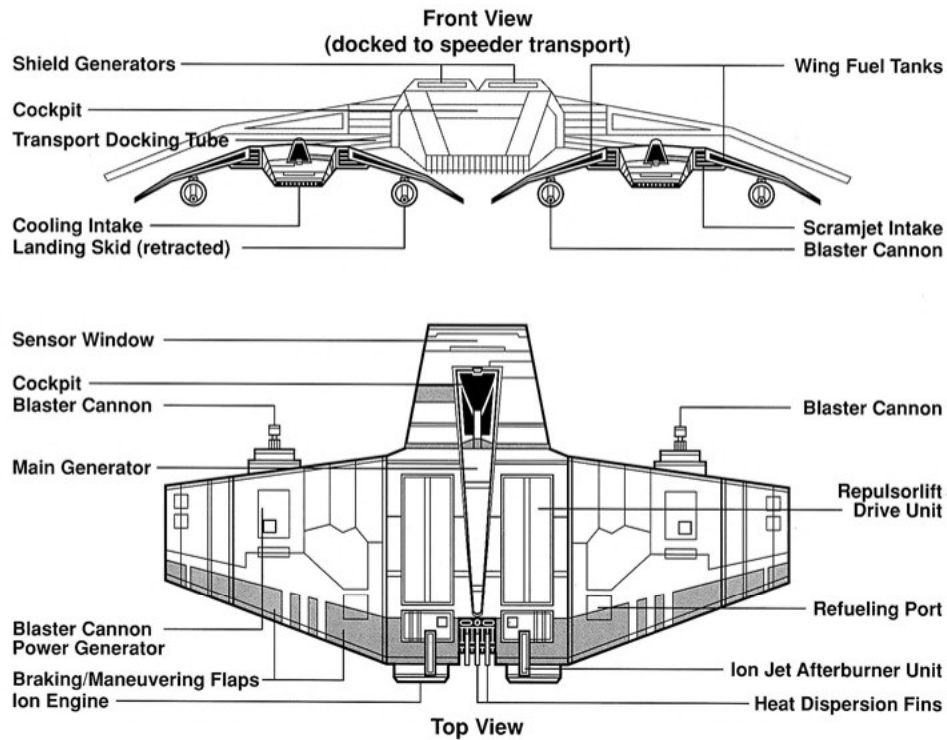

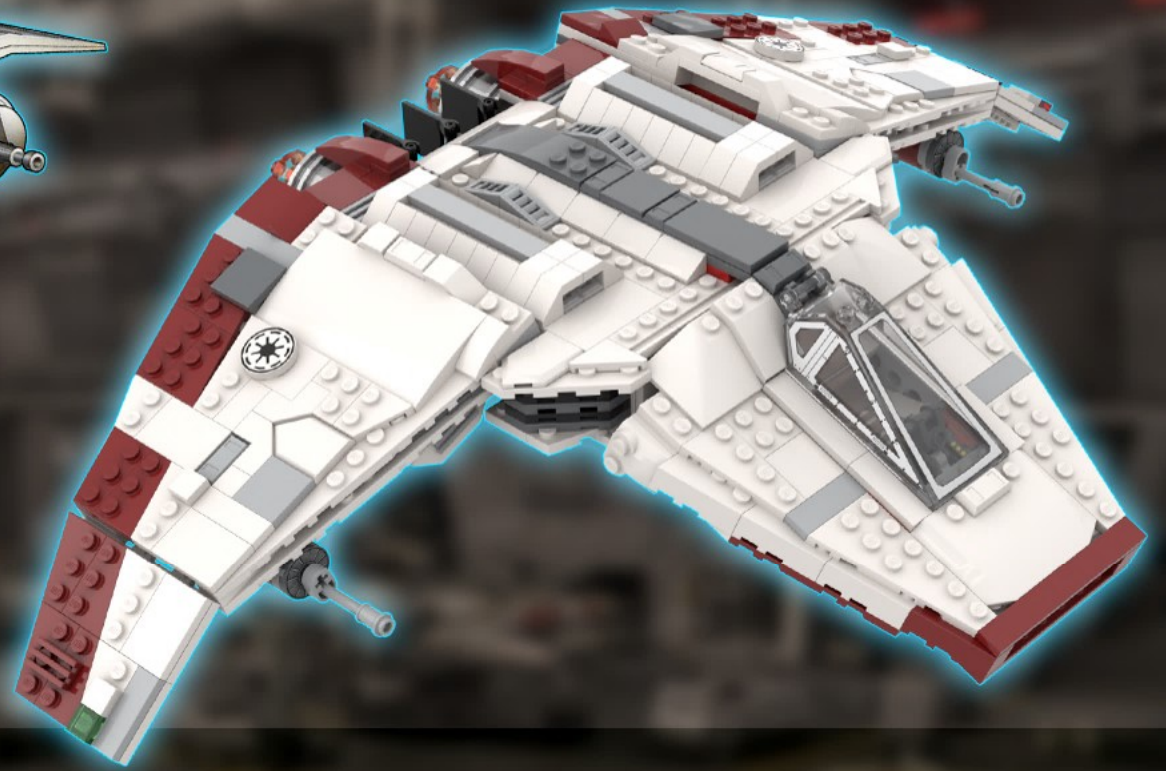
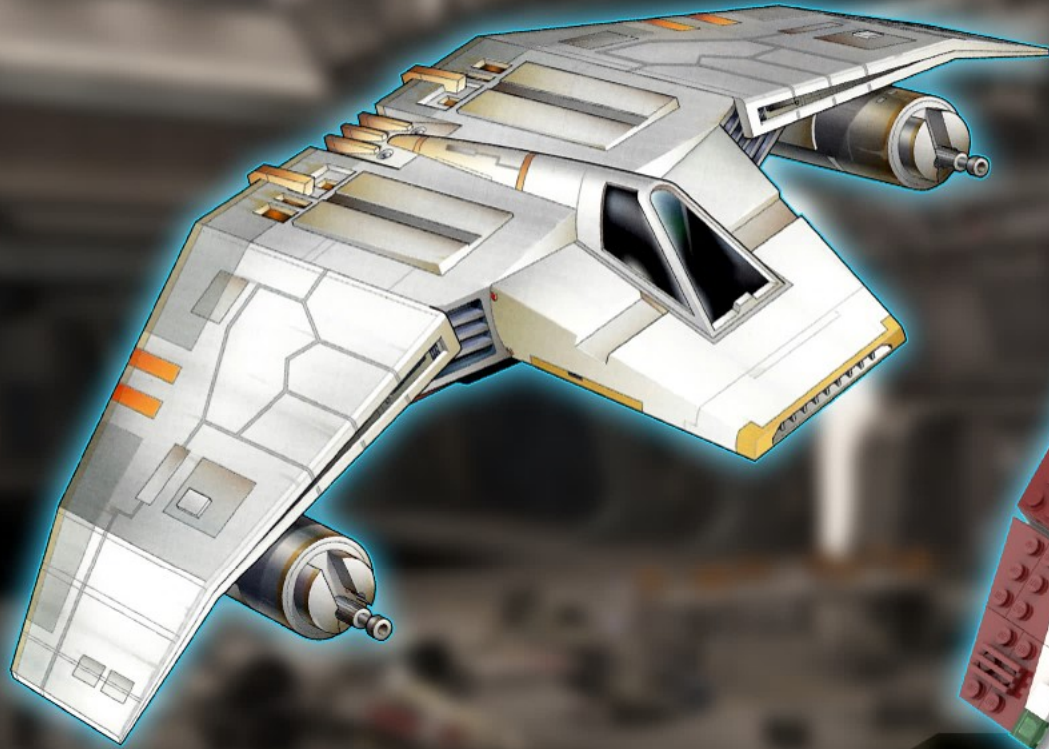

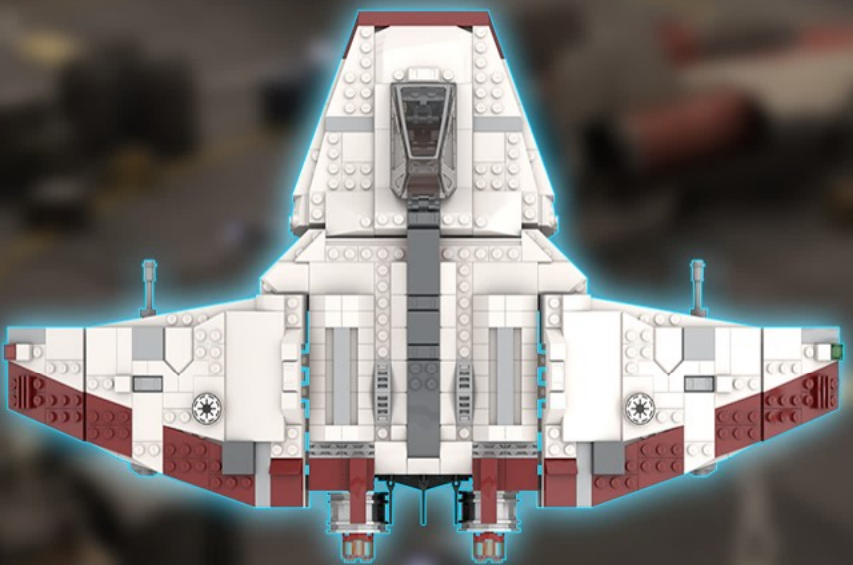
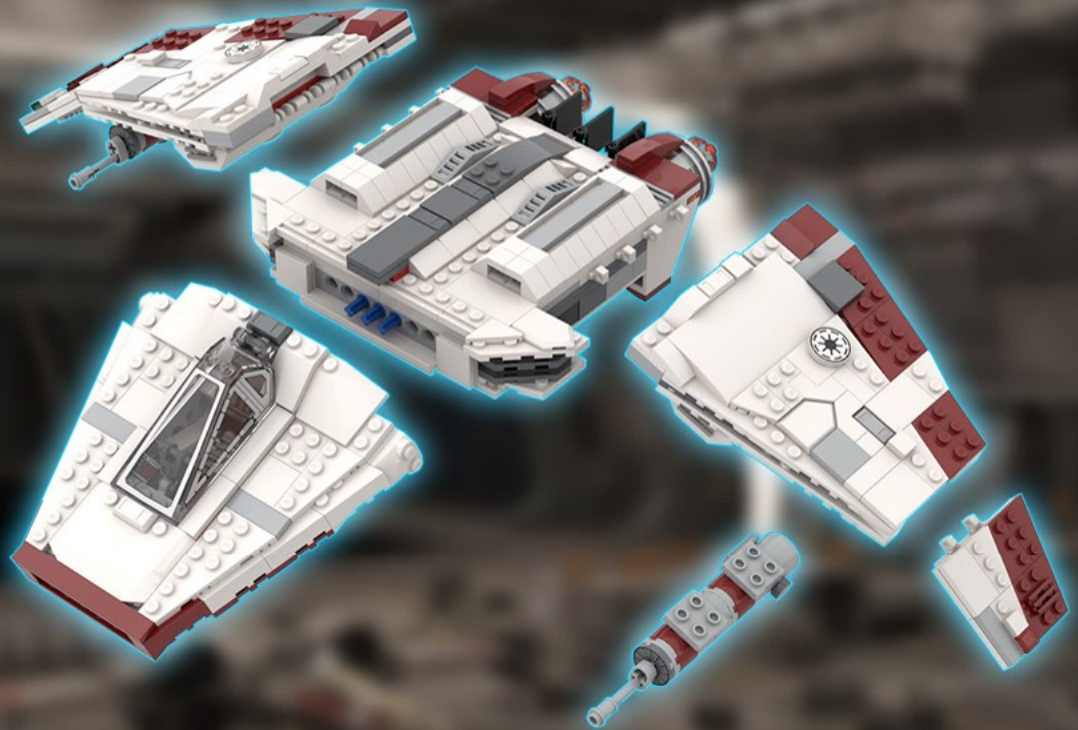
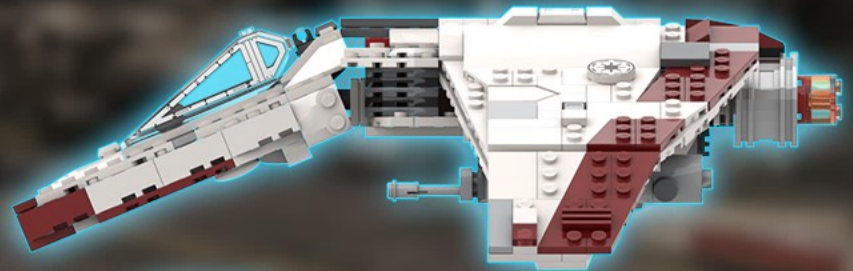

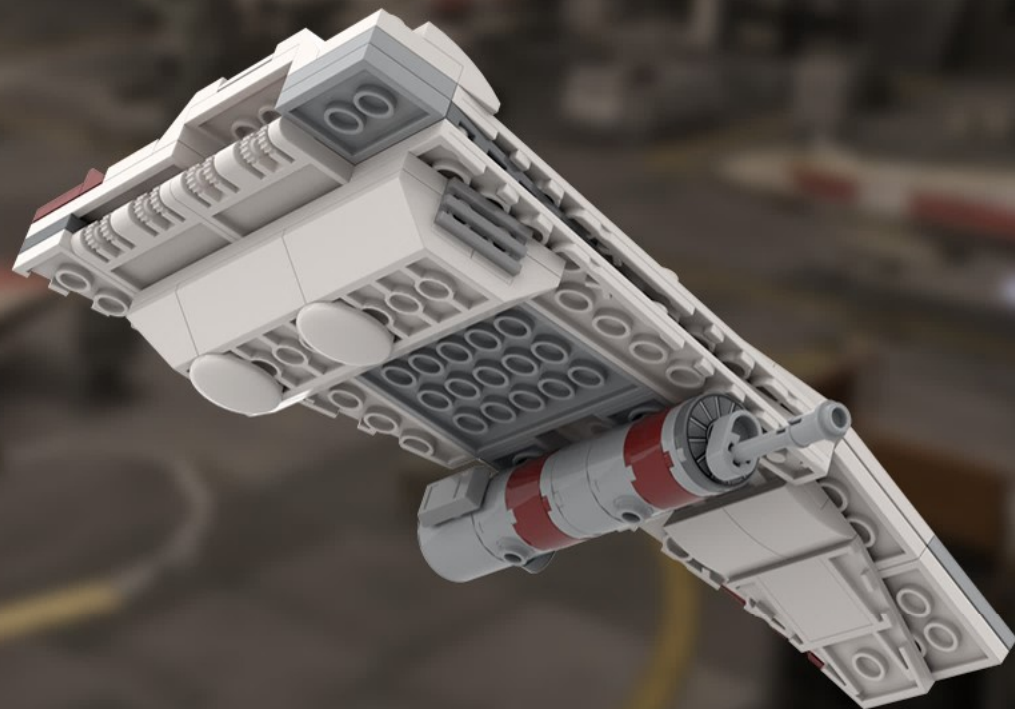
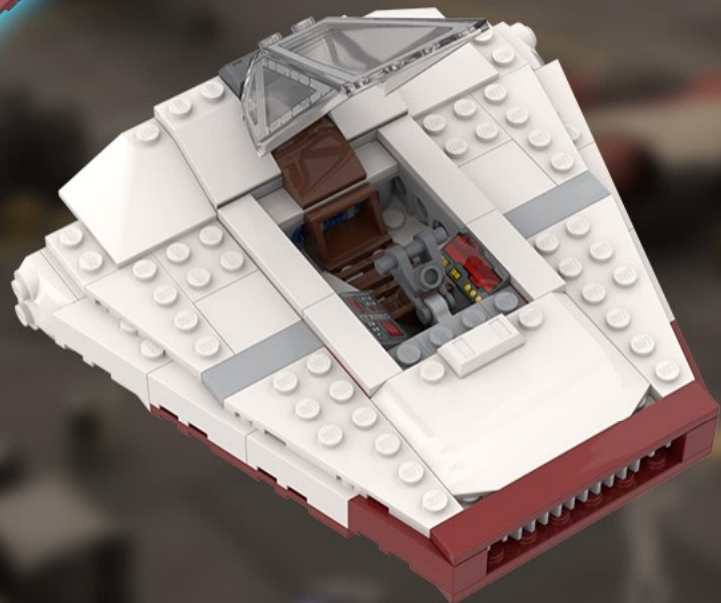
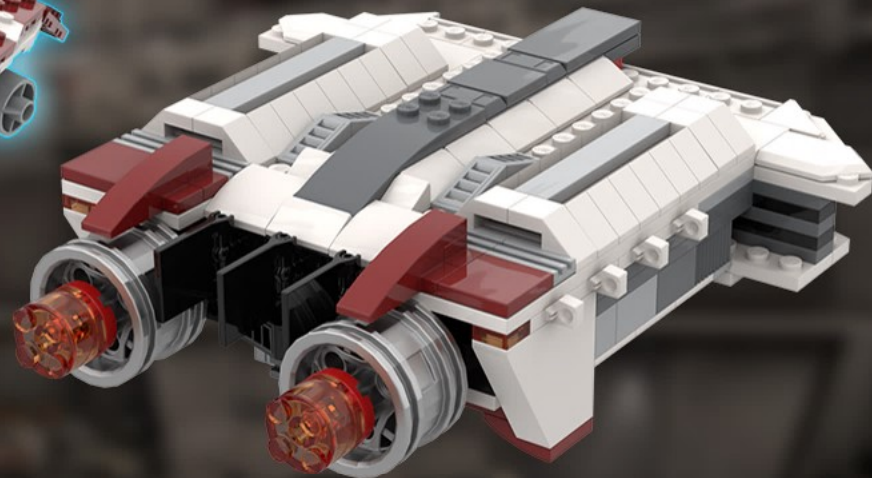

34

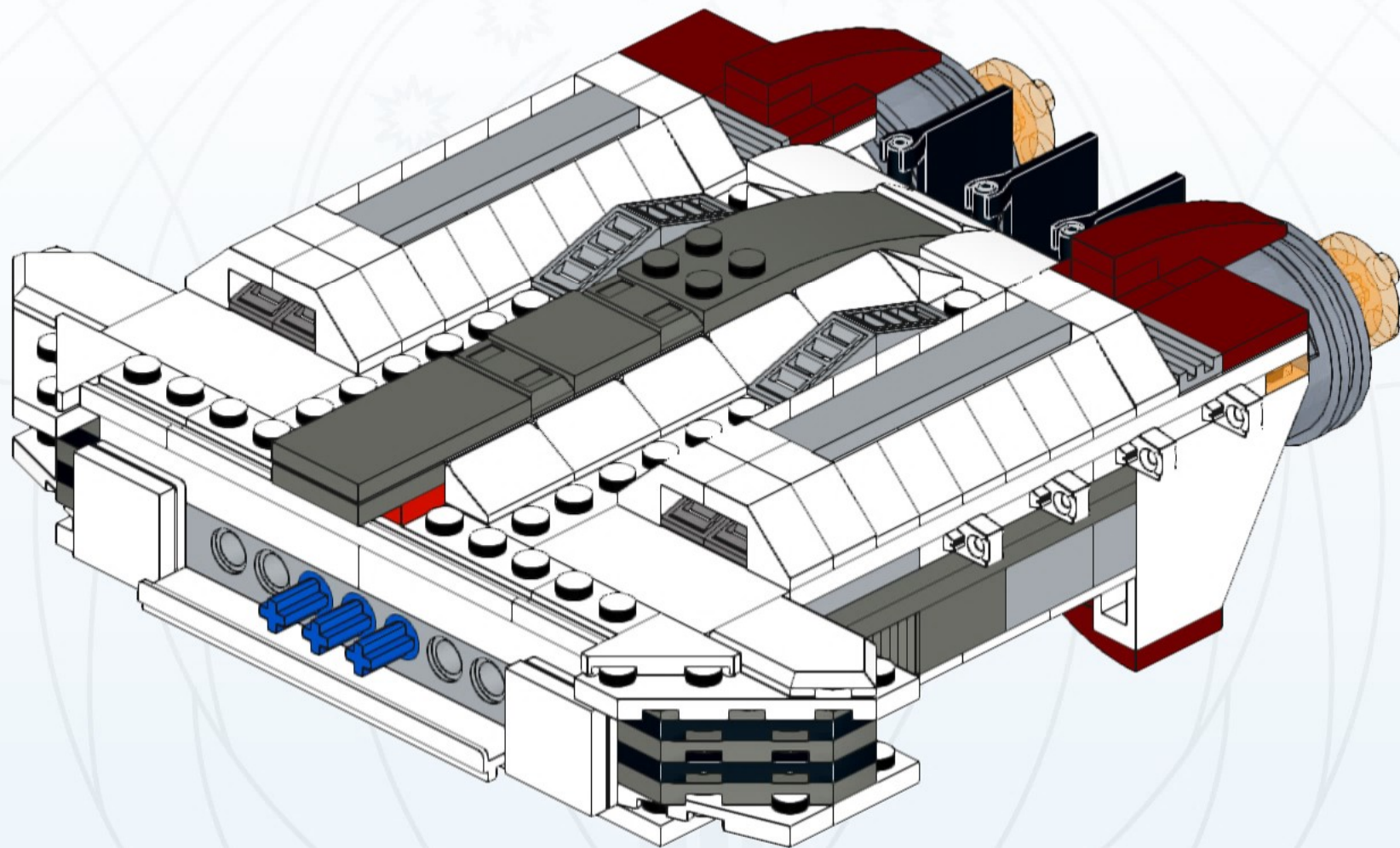

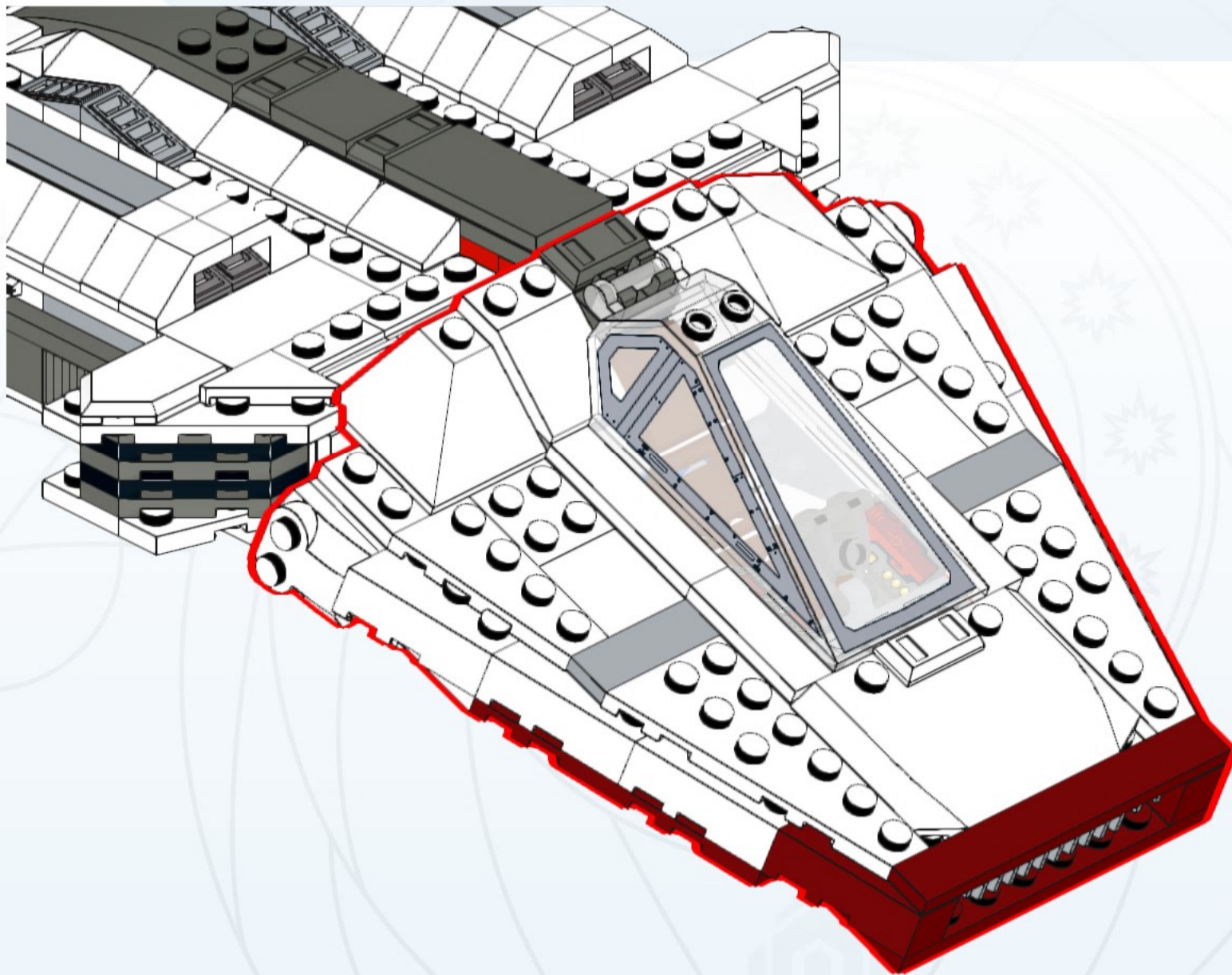

83

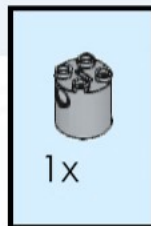
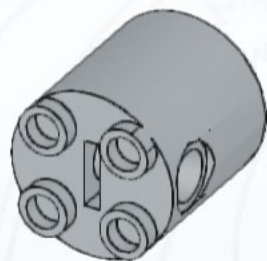
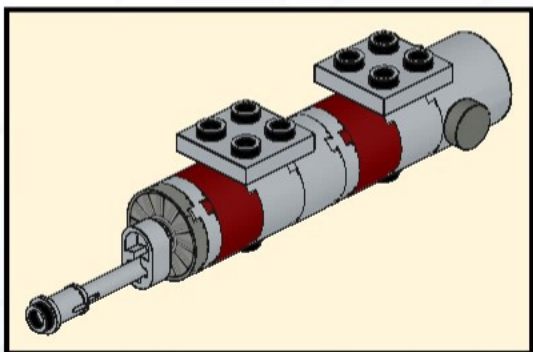

85

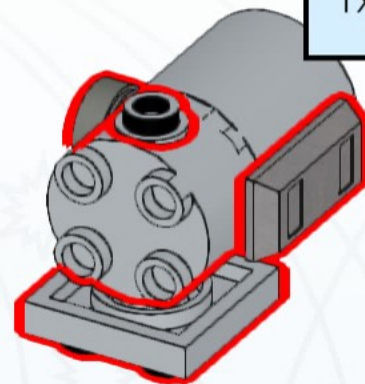
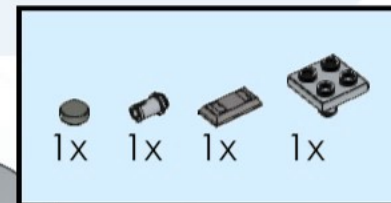

84

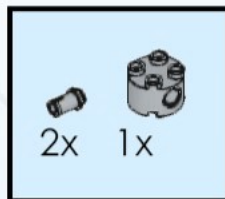
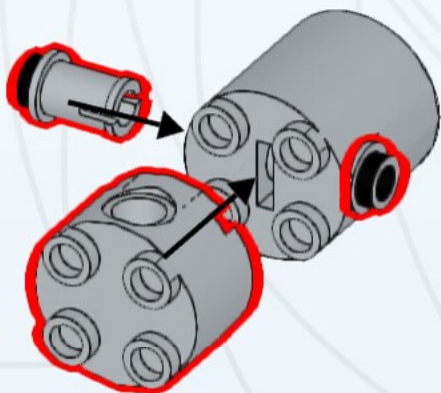

86

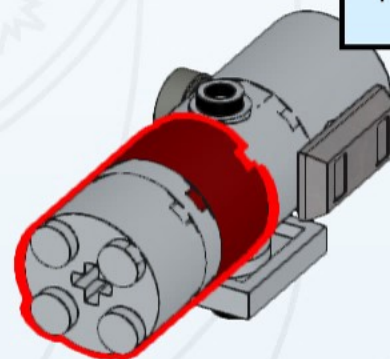
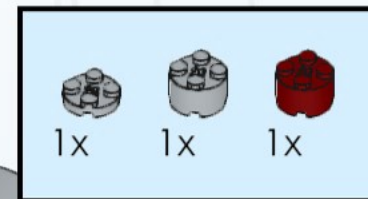

87

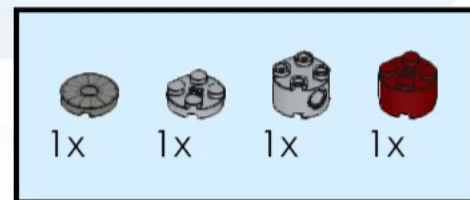
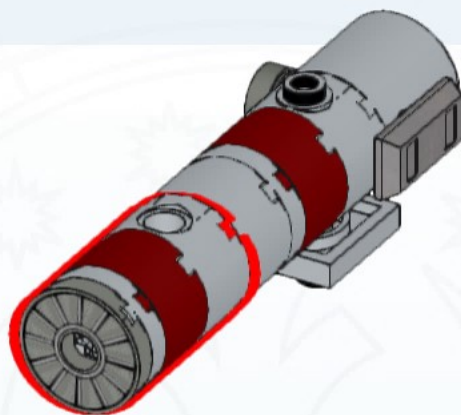

88

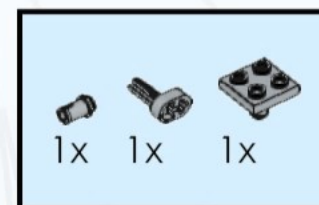
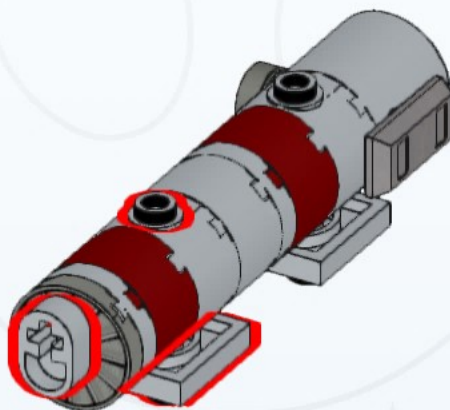

89

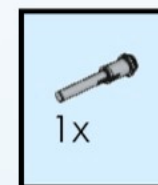
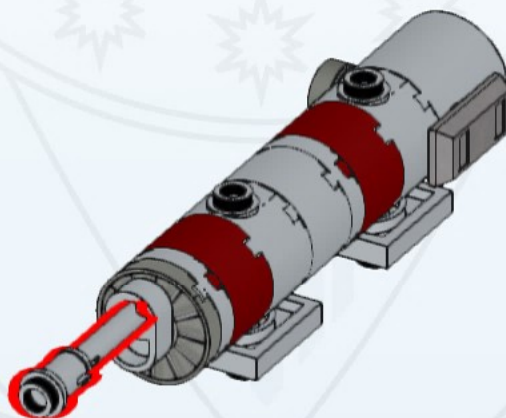

121

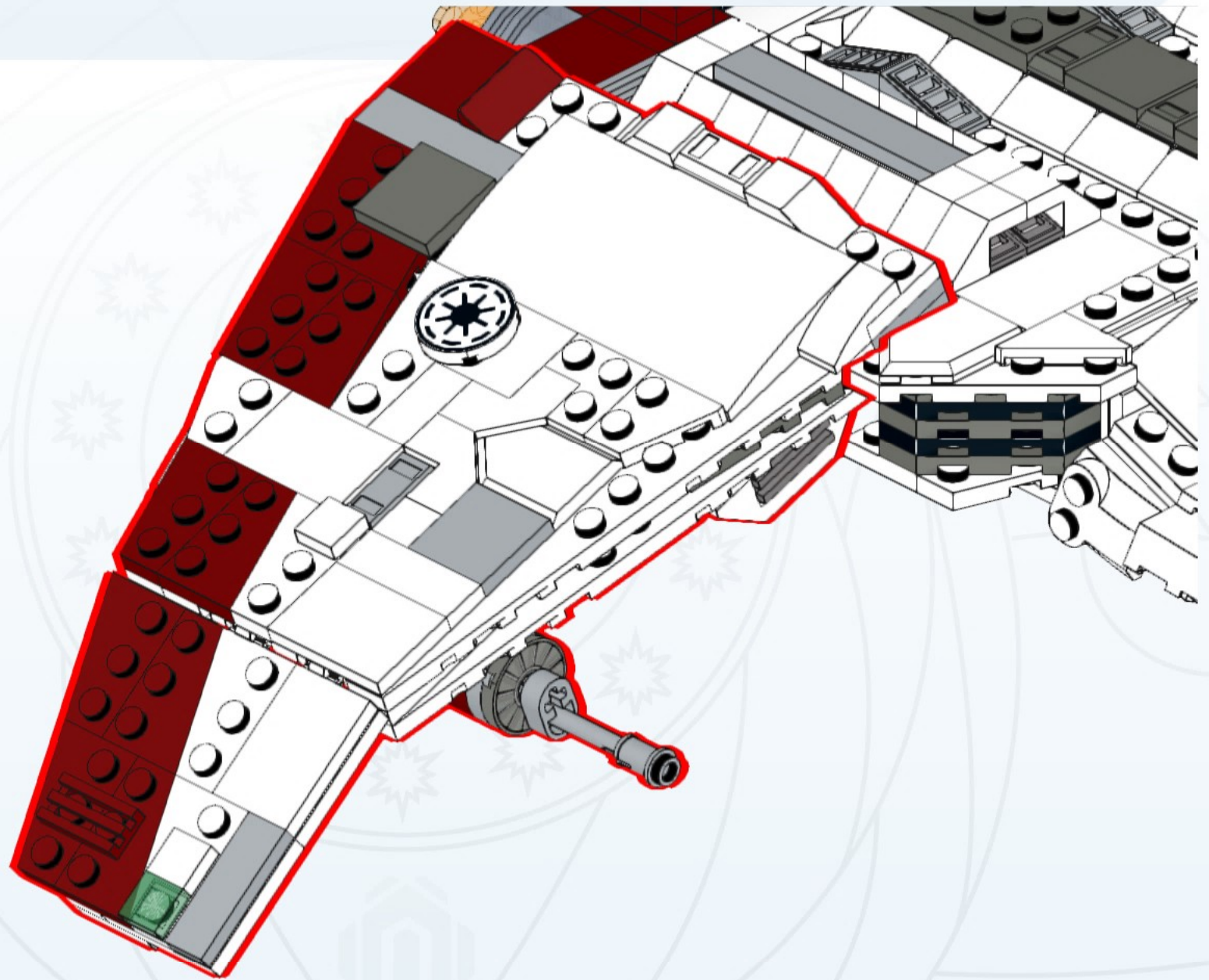





SPECIAL THANKS



Rebrickable

PROJECT CREATED WITH

